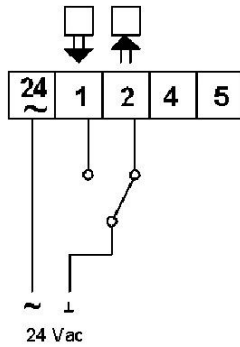

- Easy to install
- Precise positioning
- Manuel override
- High closing pressure
- Compatible with Ontrol valves

Electrical connection

Cable sizing: 3x1.5 mm²

Closing pressures

Closing Pressure (Bar)		
DN	VGf2 (2 way)	VGf3 (3 way)
15	16	16
20	16	16
25	16	16
32	16	16
40	13	16
50	7.5	10
65	4.7	6.5
80	2.3	4
100		2.3
125		0.9
150		0.9

Technical Data

Nominal Voltage	24 VAC (20.4 ... 26.4 VAC)
Power Consumption	11 VA
Control Type	Floating (3-Point)
Nominal Stroke	20 mm (MVS-20NF-24) 38 mm (MVS-38NF-24)
Manuel Override	With wheel, automatic reset
Actuating Time	114 sec. / 20 mm (MVS-20NF-24) 210 sec. / 38 mm (MVS-38NF-24)
Actuating Force	1800 N
Position Indication	Mechanically, %0...100
Ambient Temperature	0°...+45°C
Ambient Humidity	95 %rh (non-condensating)

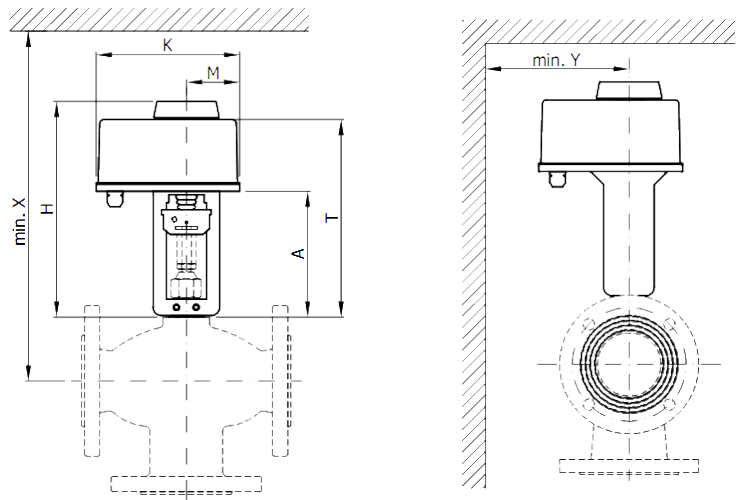
Dimensions and Weight

MODEL	A (mm)	T (mm)	H (mm)	K (mm)	M (mm)	Min. X (mm)	Min. Y (mm)	Weight (kg)
MVS-20NF-24	139	230	256	178	64	600	110	2.2
MVS-38NF-24	201	292	318	178	64	780	150	2.7

Product Features

General MVS (F) series valve actuators are used for positioning three-way or two-way control valves in heating, ventilating and air conditioning systems. Compatible with control panels with two-position (on-off) or three-position (24 VAC, floating) outputs.

Normal operation The actuator is installed to the valve shaft by means of a clamp lock and the assembly is completed by tightening two hex screws. A factory-set power limiting circuit protects the motor by cutting off the power in case of excessive stress.

Manual override All models without spring return have a manual control mechanism that allows the valve to be positioned in case of power failure. This mechanism is active during power failure. When the actuator is energized again, it returns to automatic operation without any intervention.



Important Note: It is possible to close the valve too tightly with the manual control mechanism. In this case, when the actuator is re-energized, actuating force of the electric motor may not be enough to free the valve from the jammed position. This is corrected by turning the wheel mechanism manually just one tour.

Mounting Instructions

Before start:

- For 2 way valve, **push** the stem down
- For 3 way valve **pull** the stem up

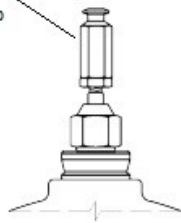

Stroke adjustment:

- 2 way valve DN15...80 stroke = 89 mm
- 3 way valve DN15...80 stroke = 107 mm
- All valve DN100...150 stroke = 170 mm

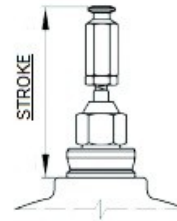

By using the wheel manually adjust the connection according to stem height

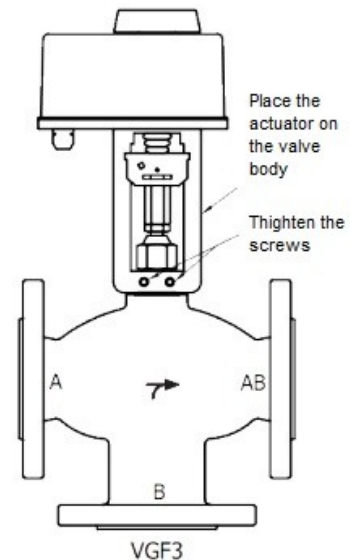
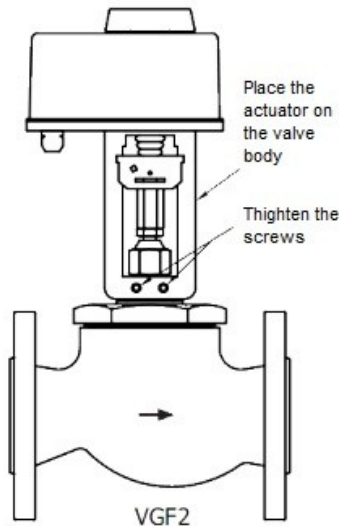
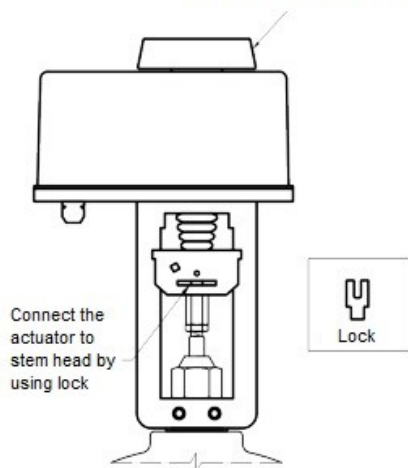

Caution by mechanical installation!

- The valve body should be mounted according to the flow direction of fluid.
- There should be enough space on the valve body to install and remove the actuator.
- For installation a 17 mm wrench (24 mm for valves of DN 100-150) and a 4 mm hex wrench are required.
- Prevent water from spilling on the actuator.